

AXIS 241Q/S Blade - Rack Solution

Installation Guide

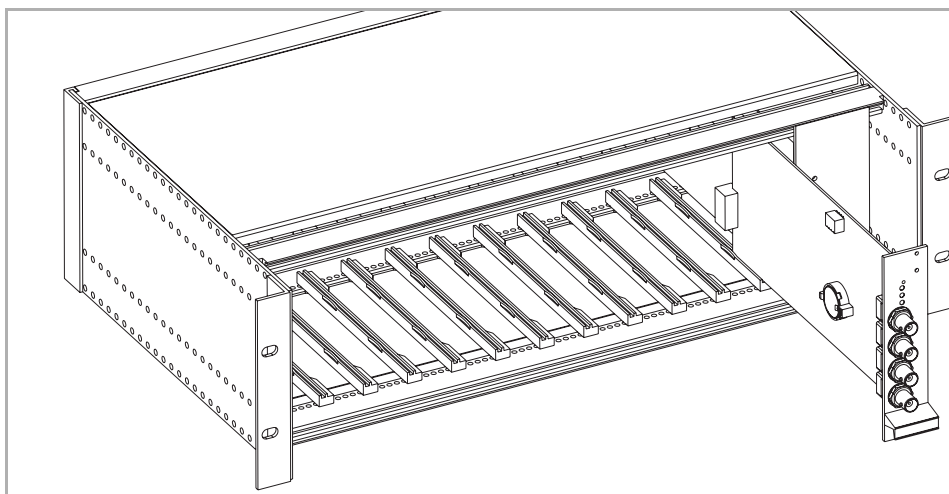

2 About This Document

This document is intended as an addendum to the video server User's Manual. It includes instructions for installing the Axis Rack Mounted Video Server Solution on your network. Later versions of this document will be posted to the Axis Web site, as required.

Intellectual Property Rights – Axis AB has intellectual property rights relating to technology embodied in the product described in this document. In particular, and without limitation, these intellectual property rights may include one or more of the patents listed at <http://www.axis.com/patent.htm> and one or more additional patents or pending patent applications in the US and other countries.

Legal Considerations – Camera surveillance can be prohibited by laws that vary from country to country. Check the laws in your local region before using this product for surveillance purposes.

Electromagnetic Compatibility (EMC) – This equipment generates, uses, and can radiate radio frequency energy, and if not installed and used in accordance with the instruction manual, may cause interference to radio communications. Shielded cables should be used to ensure compliance with EMC standards.

US – This equipment has been tested and found to comply with the limits for a Class B digital device, pursuant to Part 15 of the FCC Rules. These limits are designed to provide reasonable protection against harmful interference in a residential installation. This equipment generates, uses and can radiate radio frequency energy and, if not installed and used in accordance with the instructions, may cause harmful interference to radio communications. However, there is no guarantee that interference will not occur in a particular installation. If this equipment does cause harmful interference to radio or television reception, which can be determined by turning the equipment off and on, the user is encouraged to try to correct the interference by one or more of the following measures: Reorient or relocate the receiving antenna. Increase the separation between the equipment and receiver. Connect the equipment into an outlet on a circuit different from that to which the receiver is connected. Consult the dealer or an experienced radio/TV technician for help.

Europe – **CE** This digital equipment fulfills the requirements for radiated emission according to limit B of EN55022, and the requirements for immunity according to EN55024 residential, commercial, and light industry.

Japan – This is a class B product based on the standard of the Voluntary Control Council for Interference from Information Technology Equipment (VCCI). If this is used near a radio or television receiver in a domestic environment, it may cause radio interference. Install and

use the equipment according to the instruction manual

Australia – This electronic device meets the requirements of the Radio communications (Electromagnetic Compatibility) Standard 1998 AS/NZS 3548. Compliance is not valid for unshielded network cables.

Liability – Every care has been taken in the preparation of this manual; Please inform your local Axis office of any inaccuracies or omissions. Axis Communications AB cannot be held responsible for any technical or typographical errors and reserves the right to make changes to the product and manuals without prior notice. Axis Communications AB makes no warranty of any kind with regard to the material contained within this document, including, but not limited to, the implied warranties of merchantability and fitness for a particular purpose. Axis Communications AB shall not be liable nor responsible for incidental or consequential damages in connection with the furnishing, performance or use of this material.

Trademark Acknowledgments – Acrobat, Adobe, Boa, Ethernet, IBM, Internet Explorer, LAN Manager, Linux, Macintosh, Microsoft, Netscape Navigator, OS/2, UNIX, Windows, WWW are registered trademarks of the respective holders. Java and all Java-based trademarks and logos are trademarks or registered trademarks of Sun Microsystems, Inc. in the United States and other countries. Axis Communications AB is independent of Sun Microsystems Inc.

Support Services – Should you require any technical assistance, please contact your Axis reseller. If your questions cannot be answered immediately, your reseller will forward your queries through the appropriate channels to ensure a rapid response. If you are connected to the Internet, you can:

- download user documentation and firmware updates
- find answers to resolved problems in the FAQ database. Search by product, category, or phrases
- report problems to Axis support staff by logging in to your private support area

Visit the Axis Support Web at www.axis.com/techsup

Battery Replacement – The Axis Rack Mounted Video Server Solution uses a 3.0V CR2032 Lithium battery as the power supply for its internal real-time clock (RTC). This battery will, under normal conditions, last for a minimum of 5 years. Low battery power affects the operation of the RTC, causing it to reset at every power-up. A log message will appear when battery replacement is required. The battery should not be replaced unless required! If the battery needs replacing, please observe the following points:

- Caution! Danger of explosion if battery is incorrectly replaced
- Replace only with the same or equivalent battery, as recommended by the manufacturer
- Dispose of used batteries according to the manufacturer's instructions

The Axis Video Server Rack will fit up to 12 rack mounted Axis Video Servers (Blade Servers). This installation guide describes the hardware installation of the Axis Rack Mounted Video Server Solution. The AXIS 241Q/S Video Server User’s Manual contains additional instructions on the following:

- Installing the video server
- Configuring the video server
- Using the video server
- Troubleshooting
- Updating the software
- Customizing the video server

Hardware Inventory - AXIS Video Server Rack

Please contact your dealer if anything is missing or damaged.

Qty	Item	Product Name/Title	Country
1	Video server rack	AXIS Video Server Rack	
5	Cover plates	Cover plate 12TE	
1	Cover plate	Cover plate 6TE	
2	Connectors	Terminal Connectors 6p	
1	Power supply	Power Supply 19" 100W	
1	Power Cable	Mains Cable IEC	Europe
	<i>Country-specific: ensure that the correct adapter is used</i>		UK
			US / Japan
			Australia
1	Warranty Document		

Hardware Inventory - Axis Blade Video Server

Please contact your dealer if anything is missing or damaged.

Qty	Item	Title/Variants
1	Video servers	AXIS 241Q Blade
		AXIS 241S Blade
2	Connectors	Terminal Connectors 14p
1	Warranty Document	
1	User's Manual	AXIS 241Q/S User's Manual
1	This Document	AXIS 241Q/S Blade - Rack Solution Installation Guide
Optional Accessory		
	ACC Y/C TO BNC CABLE (AXIS 241S Blade only)	

AXIS 241Q/S Blade Video Server

Read the following information to familiarize yourself with the AXIS 241Q/S Blade video server making particular note of where the connectors and indicators are located:

Control Button

See the AXIS 241Q/S User's Manual for information on the use of the control button.

Indicators

Network	Amber	Flashes for activity on a 10 Mbit/s network
	Green	Flashes for activity on a 100 Mbit/s network
	Red	Flashes rapid red for hardware error, together with the Status indicator
	None	No connection
Status	Green	Normal operation
	Amber	Flashes during reset to factory default or at firmware upgrade
	Red	Flashes rapid red for a hardware error, together with the Network indicator
Power	Green	Normal operation
	Amber	Flashes green/amber during upgrade

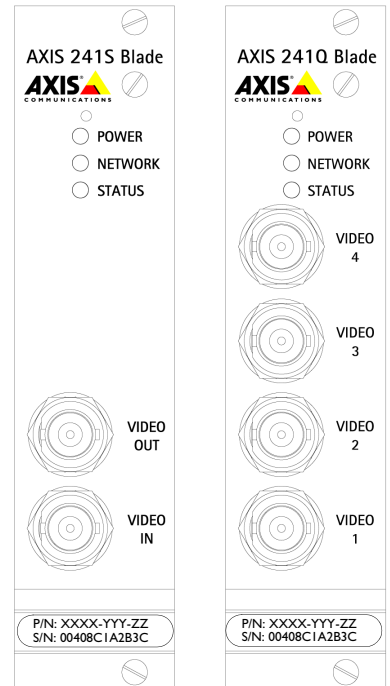

Top and bottom screws are used to secure the blade server in the rack

Video In/Out

AXIS 241Q Blade - Accommodates up to 4 separate video sources (VIDEO 1- VIDEO 4) simultaneously. Each supported video input is terminated using a coax/BNC connector. Physical connections made using RG59 75 Ohm coax video cable have a recommended maximum length of 800 feet (250 meters).

AXIS 241S Blade - Coaxial BNC connector supporting a single video source. The physical connection is made using RG59, 75 Ohm coax video cable; with a recommended maximum length of 800 feet (250 meters).

- A single video loopthrough (VIDEO OUT) connected in parallel with VIDEO IN and terminated with a coax/BNC connector allows direct connection of an external monitor. Set dip switch to OFF when in use.
- The AXIS 241S Blade supports conversion between composite video and Y/C (s-video) using a Y/C to BNC cable (available as optional accessory). See the table on page 5 for DIP switch settings.

Product Label

S/N (serial number) is identical to the unit's MAC/Ethernet address, e.g. 00408C1A2B3C = 00-40-8C-1A-2B-3C. P/N (part number) is the product model number.

Bus Connector - Physical interface to the I/O Block Connector on the rack

DIP Switch(es) - A corresponding line termination switch for each of the supported video outputs (1-4 video outputs depending on the model).

- All units are shipped with the line termination enabled for each supported video input; that is, with the DIP switches set to ON (Down position).
- If the AXIS 241Q Blade is to be connected in parallel with other equipment, disable the input termination by setting the corresponding DIP switch to OFF (Up position). Failure to do this can cause the picture quality to be impaired.
- The AXIS 241S is delivered configured for composite video input:

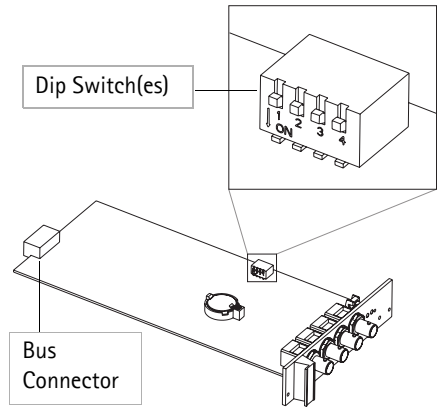

Switch	1	2	3	4
Description	75 ohm video in termination	75 ohm video out termination	connects video in and video out	Not used
Composite video input	on	off	on	n/a
Y/C video input	on	on	off	n/a

Axis Video Server Rack

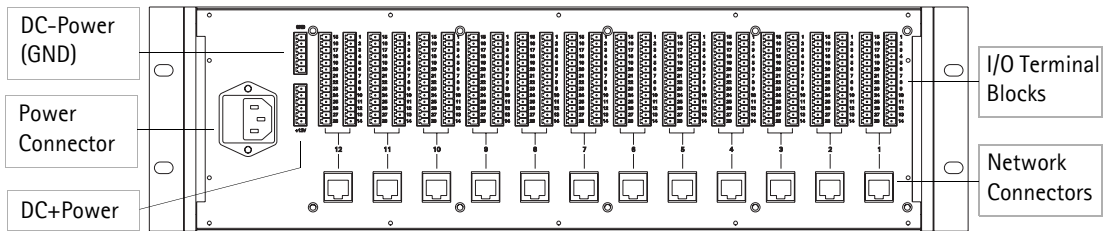

The I/O Terminal Block - the physical interface to a relay switch output and four digital photo-coupled inputs; also providing an RS-485 interface and an RS-232 serial connection.

Network Connector - Axis blade video servers are designed for 10 Mbps Ethernet /100 Mbps Fast Ethernet networks and connect to the network via a standard RJ 45 connector.

DC + Power 12VDC Power (output) - This connector can drive the photo coupler inputs or other equipment such as an IR-sensor. A maximum current (for all pins) of 1000mA can be sourced from the DC output.

Power Connector - Input power: 100-240 VAC, 50-60 Hz, 1.6A

The I/O Terminal Block

Axis Blade Video Servers connect to an I/O terminal block used for transmitting data over multi-drop communication lines:

- RS-485 Pan/Tilt devices
- RS-232 Pan/Tilt devices
- External triggering (typically associated with CCTV equipment)

The Axis Blade Video Servers support several Pan/Tilt device drivers that are available from the Axis Web site at www.axis.com

Connector Pinout

The pinout for the I/O Terminal Block and the signaling details for each pin:

Pin	Function	Description	Pin	Function	Description
1	RS-232	RI	15	RS-485 - A (non-inverting)	A half-duplex RS-485 interface for controlling auxiliary equipment, e.g. PTZ devices
2	RS-232	CTS	16	RS-485 - B (inverting)	
3	RS-232	RTS	17	Transistor Output 4	With a maximum load of 100mA and maximum voltage of 24V DC, this output has an open-collector NPN transistor with the emitter connected to GND. If it is to be used with an external relay, a diode must be connected in parallel with the load for protection against any voltage transients
4	RS-232	DSR	18	GND	
5	GND		19	Transistor Output 3	See Transistor Output 4 (above)
6	RS-232	DTR	20	Transistor Output 2	See Transistor Output 4 (above)
7	RS-232	TXD	21	GND	
8	RS-232	RXD	22	Transistor Output 1	See Transistor Output 4 (above)
9	RS-232	CD	23	Digital Input 4	Connect to GND to activate or leave floating (or unconnected) to deactivate
10	GND		24	GND	
11	n/a		25	Digital Input 3	See Digital Input 4 (above)
12	n/a		26	Digital Input 2	See Digital Input 4 (above)
13	n/a		27	GND	
14	n/a		28	Digital Input 1	See Digital Input 4 (above)

For compatible replacement connectors, contact <http://www.phoenixcontact.com>, quoting: MC1.5/14-ST-3.81 (art no 1803691)

For further information, please refer to the Unit Connections section in the AXIS 241Q/S User's Manual.

Connecting the video server to the rack

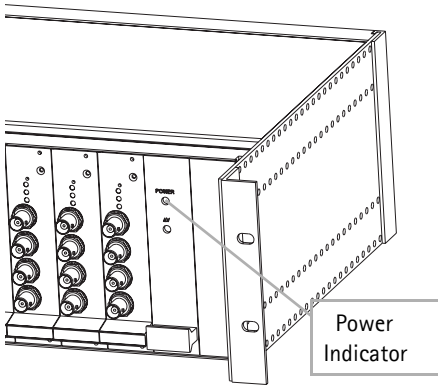

Please read through the instructions below before beginning the installation.

1. Connect the power cable to the power connector on the rack. Make sure that the green power indicator is lit.
2. Note the Serial number (S/N) on the front panel on the video server. You need to know this to set the IP address.

3. Now refer to **Installing on a Network** in the AXIS 241Q/S Video Server User's Manual supplied with the Axis Blade Video Server, keeping in mind the following details:
 - **Network** - connect the Ethernet cable to the Ethernet connector on the rack, in the position where the video server is to be connected.
 - **Power** is supplied via the Bus Connector, slide the blade video server into the slot. Make sure that the bus connector is securely connected to the I/O terminal block connector at the back of the rack. When repeating the installation procedure for each individual blade video server, simply disconnect the blade video server from the rack (i.e. do not disconnect the power cable).
 - Secure the video server to the rack using the screws on the front panel. The rack accommodates up to 12 individual Axis Video Servers. To comply with EMC regulations, ensure that all empty slots are covered using the supplied cover plates.

AXIS 241Q/S Video Server User's Manual

The functionality of the Axis Blade Video Servers is the same as in the standalone versions. For more information on how to install and configure your video server rack on your network, please refer to the relevant sections in the AXIS 241Q/S Video Server User's Manual available in printed format with your AXIS 241Q/S Video Server or on the Axis Web site at www.axis.com

Technical Specifications

The following specifications are applicable for the complete Axis Rack Mounted Video Server Solution i.e. an AXIS Video Server Rack with a mounted AXIS 241Q/S Blade Video Server.

Safety Approvals – EN60950

EMC Approvals –

- EN 55 024:1998 + A1
- EN 55 022:1998 + A1 (CISPR 22:1997 + A1) Class B
- EN 61000-3-2:2000
- EN 61000-3-3:1995 + A1
- VCCI:2002 Class B ITE (CISPR 22:1997 + A1:2000, Class B)
- C-tick AS/NZS 3548
- FCC part 15, subpart B, Class B, demonstrated by compliance with EN 55022:1998 (CISPR 22:1997) Class B

Metrics – Rack: Height: 5.2" (13.2 cm), Width: 19.0" (48.2 cm), Length: 11.8" (30.0 cm), Weight: 7.3 lb (3.3 kg). Video Server: Height: 1.2" (3.1 cm), Width: 5.1" (12.9 cm), Length: 10.0" (25.5 cm), Weight: 0.5 lb (0.23 kg)

Power – Input Power: 100-240 VAC, 50-60 Hz, 1.6A

Operating Conditions – Temp: 40° to 125°F (5° to 50°C), Humidity: 20-80% RHG

All specifications are subject to change without prior notice.

Additional Technical Details

For additional technical details see the **Technical Specifications** section in the AXIS 241Q/S User's Manual. The manual is available in printed format with your AXIS 241Q/S Blade Video Server or on the Axis Web site at <http://www.axis.com>